

WQS(C 款)产品概述

WQS 排污泵是在引进国外先进技术的基础上，结合国内水泵的使用特点而研制成功的新一代泵类产品。污水泵具有节能效果显著、防缠绕、无堵塞、自动安装和自动控制等特点。

在排送固体颗粒和长纤维垃圾方面，具有独特效果。该系列泵采用独特叶轮机构和新型机械密封。能有效地输送含固体物和长纤维。叶轮与传统叶轮相比。该泵叶轮采用流道或双流道形式。它类似于截面大小相同的弯管。具有非常好的过流性，配以合理的蜗室。使得该泵具有效率高。叶轮经动静平衡实验，使污水泵在运行中无振动。

WQS(C 款)产品特点

WQS 型大流量潜水泵采用独特的双吸式双流道结构，水泵在使用过程中，水是从水泵叶轮的两端同时进水，中间流出。

该系列潜水无堵塞排污泵，属于一种潜水电机为双吸式泵的巧妙组合。使其不仅具有潜水电动的功能。又具有双吸泵高效运行平稳的特殊性能。

大流量潜水泵采用双下吸水结构吸水位低，采用双吸式双流道单蜗壳结构，电机没有了轴向拉力。减轻并平衡了轻向力。大大提高了泵的使用寿命 3 倍。提高了使用效率 15 %。

大流量潜水泵结构紧凑，体积小，移动方便，安装简便，无需建泵房。潜入水中即可工作，大大减少工程造价。

WQS (C 款) 结构示意图

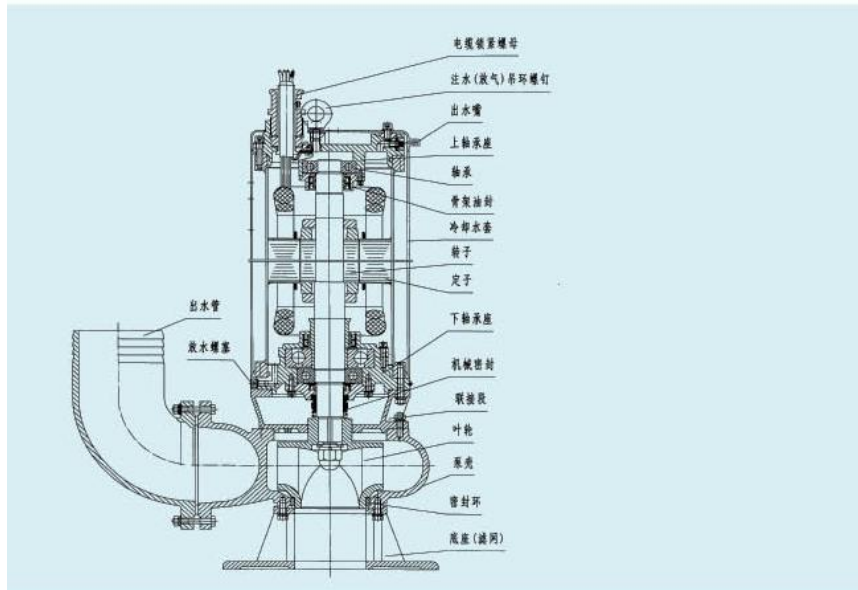

WQS (C 款) 型号说明

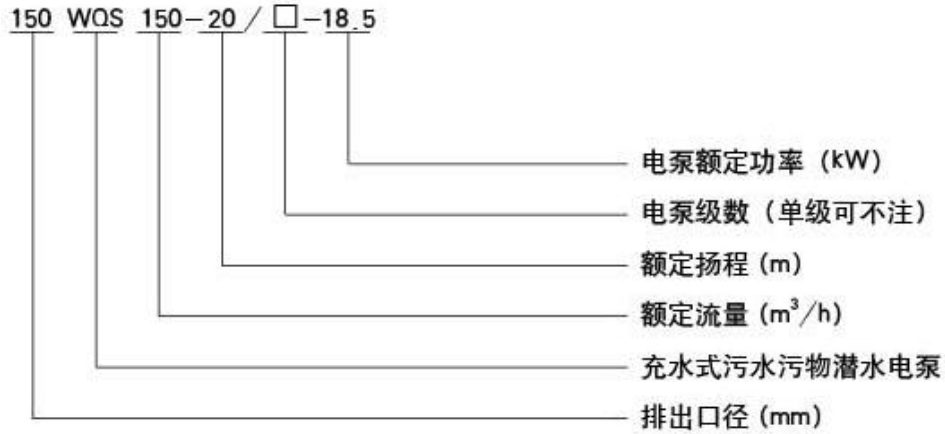

WQS (C 款) 安装尺寸

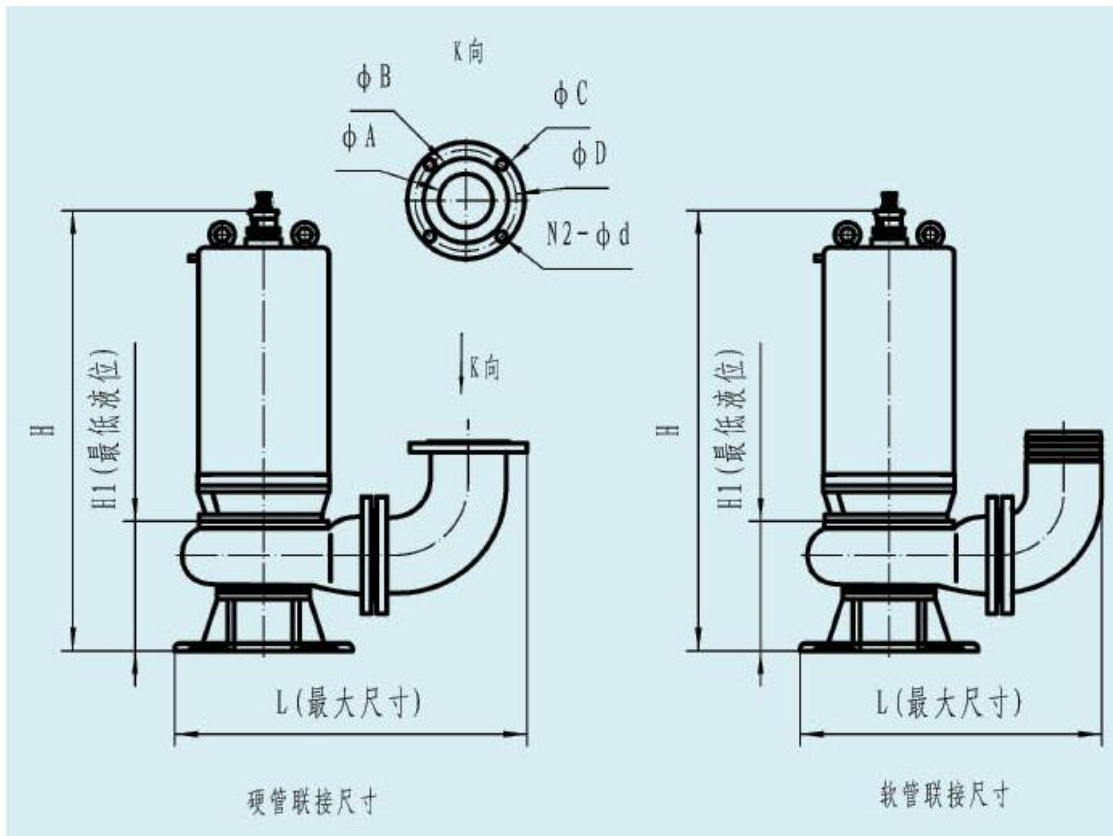

WQS (C 款) 型泵安装尺寸表

WQS (C section) pump installation dimensions table

序号	型号	硬管连接尺寸								软管连接尺寸			
		ΦA	ΦB	ΦC	ΦD	N2-Φd	H	H1	L	ΦD	L	H	H1
1	65WQS15-40-5.5	65	110	160	130	4-Φ13.5	705	120	380	65	365	705	120
2	80WQS30-20-5.5	80	128	190	150	4-Φ17.5	775	190	400	80	385	775	190
3	65WQS15-50-7.5	65	110	160	130	4-Φ13.5	725	120	400	65	385	725	120
4	65WQS20-45-7.5	65	110	160	130	4-Φ13.5	745	140	370	65	355	745	140
5	80WQS50-30-7.5	80	128	190	150	4-Φ17.5	745	140	385	80	355	745	140
6	100WQS100-12-7.5	100	148	210	170	4-Φ17.5	840	235	595	10	515	840	235
7	80WQS50-20-7.5	80	128	190	150	4-Φ17.5	805	200	415	80	385	805	200
8	80WQS70-15-7.5	80	128	190	150	4-Φ17.5	825	220	570	80	470	825	220
9	80WQS30-35-7.5	80	128	190	150	4-Φ17.5	745	140	385	80	355	745	140
10	65WQS15-60-9.2	65	110	160	130	4-Φ13.5	770	120	400	65	385	770	120
11	80WQS30-45-9.2	80	128	190	150	4-Φ17.5	790	140	385	80	355	790	140
12	150WQS140-10-9.2	150	202	265	225	4-Φ17.5	974	270	750	155	605	974	270
13	100WQS100-15-9.2	100	148	210	170	4-Φ17.5	885	235	595	102	515	885	235
14	80WQS70-20-9.2	80	128	190	150	4-Φ17.5	870	220	570	80	470	870	220
15	65WQS15-70-11	65	110	160	130	4-Φ13.5	830	115	445	65	430	830	115
16	80WQS50-40-11	80	128	190	150	4-Φ17.5	815	140	385	80	355	815	140
17	100WQS70-30-11	100	148	210	170	4-Φ17.5	930	225	470	102	430	930	225
18	150WQS150-10-11	150	202	265	225	4-Φ17.5	984	270	750	155	605	984	270
19	65WQS15-80-13	65	110	160	130	4-Φ13.5	850	115	445	65	430	850	115
20	80WQS60-30-13	80	128	190	150	4-Φ17.5	856	230	485	80	470	856	130
21	100WQS70-40-13	100	148	210	170	4-Φ17.5	950	225	470	102	430	950	225
22	100WQS100-20-13	100	148	210	170	4-Φ17.5	970	245	610	102	530	970	245
23	150WQS150-15-13	150	202	265	225	8-Φ17.5	1004	270	750	155	605	1004	270

WQS (C 款) 型泵安装尺寸表

WQS (C section) pump installation dimensions table

序号	型号	硬管连接尺寸								软管连接尺寸			
		Φ A	Φ B	Φ C	Φ D	N2-Φ d	H	H1	L	Φ D	L	H	H1
24	150WQS200-12-13	150	202	265	225	4-Φ 17.5	1020	285	750	155	610	1020	285
25	80WQS50-60-15	80	128	190	150	4-Φ 17.5	880	130	485	80	470	880	130
26	80WQS25-80-15	80	128	190	150	4-Φ 17.5	880	120	485	80	470	880	120
27	150WQS180-15-15	150	202	265	225	4-Φ 17.5	1028	270	750	155	605	1028	270
28	200WQS300-7-15	200	260	320	280	4-Φ 17.5	1095	340	880	200	793	1095	340
29	200WQS300-10-18.5	200	260	265	280	4-Φ 17.5	1122	340	880	200	793	1122	340
30	150WQS150-20-18.5	150	202	265	225	4-Φ 17.5	1054	270	750	155	605	1054	270
31	150WQS200-16-18.5	150	202	265	225	4-Φ 17.5	1070	285	750	155	610	1070	285
32	100WQS100-30-18.5	100	148	210	170	4-Φ 17.5	1035	260	660	102	580	1035	260
33	80WQS50-70-18.5	80	128	190	150	4-Φ 17.5	906	130	485	80	470	906	130
34	80WQS50-80-22	80	128	190	150	4-Φ 17.5	961	130	485	80	470	961	130
35	150WQS150-30-22	150	202	320	225	4-Φ 17.5	1109	270	750	155	605	1109	270
36	200WQS300-12-22	200	260	210	280	4-Φ 17.5	1177	340	880	200	793	1177	340
37	100WQS100-40-22	100	148	210	170	4-Φ 17.5	1090	260	660	102	580	1090	260
38	100WQS100-50-22	100	110	265	170	4-Φ 17.5	1090	260	660	102	580	1090	260
39	150WQS200-20-22	150	202	160	225	4-Φ 17.5	1125	285	750	155	610	1125	285
40	65WQS25-100-25	65	110	320	130	4-Φ 17.5	1054	193	525	65	500	1054	193
41	200WQS300-16-30	200	260	210	280	4-Φ 17.5	1230	340	880	200	793	1230	340
42	100WQS100-60-30	100	148	265	170	4-Φ 17.5	1165	270	690	102	610	1165	270
43	150WQS200-30-30	150	202	265	225	4-Φ 17.5	1197	305	745	155	600	1197	305
44	150WQS200-40-37	150	202	265	225	4-Φ 17.5	1239	305	745	155	600	1239	305
45	200WQS300-20-37	200	260	320	280	4-Φ 17.5	1272	340	880	200	793	1272	340

WQS (C 款) 型泵自动耦合安装尺寸

WQS (C section) pump automatic coupling installation dimensions

序号	型号	ΦA	ΦB	ΦC	ΦD	N2-Φd	H	H1	H2	H3	h	G	c	S	T	g	f	p	y	N1-Φd
1	100WQS100-12-7.5	100	148	210	170	4-Φ17.5	840	328	150	235	25	178	100	70	32	260	360	210	280	4-Φ20
2	80WQS70-15-7.5	80	128	190	150	4-Φ17.5	825	313	150	220	20	168	100	70	32	240	340	200	260	4-Φ20
3	150WQS140-10-9.2	150	202	265	225	8-Φ17.5	974	403	150	270	25	220	113	70	26	300	440	230	332	4-Φ22
4	100WQS100-15-9.2	100	148	210	170	4-Φ17.5	885	328	150	235	25	178	100	70	32	260	360	210	280	4-Φ20
5	80WQS70-20-9.2	80	128	190	150	4-Φ17.5	870	313	150	220	20	168	100	70	32	240	340	200	260	4-Φ20
6	150WQS150-10-11	150	202	265	225	8-Φ17.5	984	403	150	270	25	220	113	70	26	300	440	230	332	4-Φ22
7	100WQS100-20-13	100	148	210	170	4-Φ17.5	970	328	150	245	25	178	100	70	32	260	360	210	280	4-Φ20
8	150WQS150-15-13	150	202	265	225	8-Φ17.5	1004	403	150	270	25	220	113	70	26	300	440	230	332	4-Φ22
9	150WQS200-12-13	150	202	265	225	8-Φ17.5	1020	403	150	285	25	220	113	70	26	300	440	230	332	4-Φ22
10	150WQS180-15-15	150	202	265	225	8-Φ17.5	1028	403	150	270	25	220	113	70	26	300	440	230	332	4-Φ22
11	200WQS300-7-15	200	260	340	295	8-Φ22	1095	563	150	340	25	296	135	81.5	6	380	570	334	375	4-Φ25
12	200WQS300-10-18.5	200	260	340	295	8-Φ22	1122	563	150	340	25	220	135	81.5	6	380	570	334	375	4-Φ25
13	150WQS150-20-18.5	150	202	265	225	8-Φ17.5	1054	403	150	270	25	220	113	70	26	300	440	230	332	4-Φ22
14	150WQS200-16-18.5	150	202	265	225	8-Φ17.5	1070	403	150	285	25	178	113	70	26	300	440	230	332	4-Φ22
15	100WQS100-30-18.5	100	148	210	170	4-Φ17.5	1035	328	150	260	25	220	100	70	32	260	360	210	280	4-Φ20
16	150WQS150-30-22	150	202	265	225	8-Φ17.5	1109	403	150	270	25	296	113	70	26	300	440	230	332	4-Φ22
17	200WQS300-12-22	200	260	340	295	8-Φ22	1177	563	150	340	25	178	135	81.5	6	380	570	334	375	4-Φ25
18	100WQS100-40-22	100	148	210	170	4-Φ17.5	1090	328	150	260	25	178	100	70	32	260	360	210	280	4-Φ20
19	100WQS100-50-22	100	148	210	170	4-Φ17.5	1090	328	150	260	25	220	100	70	32	260	360	210	280	4-Φ20
20	200WQS200-20-22	150	202	265	225	8-Φ17.5	1125	403	150	285	25	296	113	70	26	300	440	230	332	4-Φ22
21	200WQS300-16-30	200	260	340	295	8-Φ22	1230	563	150	340	25	178	135	81.5	6	380	570	334	375	4-Φ25
22	100WQS100-60-30	100	148	210	170	4-Φ17.5	1165	328	150	270	25	220	100	70	32	260	360	210	280	4-Φ20
23	150WQS200-30-30	150	202	265	225	8-Φ17.5	1197	403	150	305	25	220	113	70	26	300	440	230	332	4-Φ22
24	150WQS200-40-37	150	202	265	225	8-Φ17.5	1239	403	150	305	25	296	113	70	26	300	440	230	332	4-Φ22
25	200WQS300-20-37	200	260	340	295	8-Φ22	1272	563	150	340	25	296	135	81.5	6	380	570	334	375	4-Φ25

WQS (C 款) 型泵自动耦合安装尺寸

WQS (C section) pump automatic coupling installation dimensions

P	Q	K	L	M	e	m	E
120	152	327	230	130	13	85	750X650
119	148	315	200	120	13	75	650X600
142	186	395	290	200	13	85	1000X800
120	152	327	230	130	13	85	750X650
119	148	315	200	120	13	75	650X600
142	186	395	290	200	13	85	1000X800
118	149	343	230	130	13	85	750X650
142	186	395	290	200	13	85	1000X800
142	195	398	290	200	13	85	1000X800
142	186	395	290	200	13	85	1000X800
156	230	448	380	250	13	75	1300X900
156	230	448	380	250	13	75	1300X900
142	186	395	290	200	13	85	1000X800
142	195	398	290	200	13	85	1000X800
142	162	393	230	130	13	85	750X650
142	186	395	290	200	13	85	1000X800
156	230	448	380	250	13	75	1300X900
142	162	393	230	130	13	85	750X650
142	162	393	230	130	13	85	750X650
142	195	398	290	200	13	85	1000X800
156	230	448	380	250	18	75	1300X900
158	172	422	230	130	13	85	750X650
152	182	390	290	200	13	85	1000X800
152	182	390	290	200	13	85	1000X800
156	230	448	380	250	13	75	1300X900

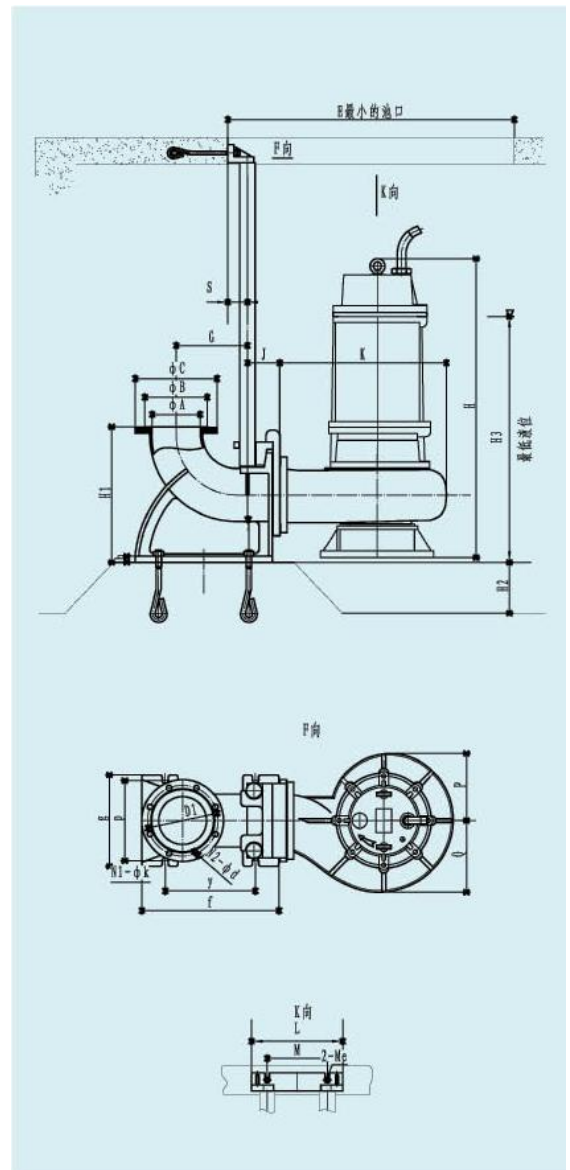

WQS (C 款) 型泵性能参数

WQS (C section) pump performance parameters

序号	口径(mm)	型号	流量 (m ³ /h)	扬程 (m)	转速 (r/min)	功率 (kw)	效率 (%)	最大通过颗粒 尺寸(mm)	自动耦合器
1	65	65WQS15-40-5.5	15	40	2900	5.5	50	20	~
2	80	80WQS30-20-5.5	30	20	2900	5.5	55	25	~
3	65	65WQS15-50-7.5	15	50	2900	7.5	50	20	~
4	65	65WQS20-45-7.5	20	45	2900	7.5	448	20	~
5	80	80WQS50-30-7.5	50	30	2900	7.5	60	30	~
6	100	100WQS100-12-7.5	100	12	2900	7.5	65	35	GAK-100
7	80	80WQS50-20-7.5	50	20	2900	7.5	60	30	~
8	80	80WQS70-15-7.5	70	15	2900	7.5	60	35	GAK-100
9	80	80WQS30-35-7.5	30	35	2900	7.5	55	25	~
10	65	65WQS15-60-9.2	15	60	2900	9.2	50	20	~
11	80	80WQS30-45-9.2	30	45	2900	9.2	55	25	~
12	150	150WQS140-10-9.2	140	10	2900	9.2	65	40	GAK-150
13	100	100WQS100-15-9.2	100	15	2900	9.2	65	35	GAK-100
14	80	80WQS70-20-9.2	70	20	2900	9.2	60	35	GAK-80
15	65	65WQS15-70-11	15	70	2900	11	50	20	~
16	80	80WQS50-40-11	50	40	2900	11	60	30	~
17	100	100WQS70-30-11	70	30	2900	11	60	35	~
18	150	150WQS150-10-11	150	10	2900	11	65	40	GAK-150
19	65	65WQS15-80-13	15	80	2900	13	50	20	~
20	80	80WQS60-30-13	60	30	2900	13	60	30	~
21	100	100WQS70-40-13	70	40	2900	13	60	35	~
22	100	100WQS100-20-13	100	20	2900	13	65	35	GAK-100
23	150	150WQS150-15-13	150	15	2900	13	65	40	GAK-150

WQS (C 款) 型泵性能参数

WQS (C section) pump performance parameters

序号	口径 (mm)	型号	流量 (m ³ /h)	扬程 (m)	转速 (r/min)	功率 (kw)	效率 (%)	最大通过颗 粒尺寸(mm)	自动耦合器
24	150	150WQS200-12-13	200	12	2900	13	70	45	GAK-150
25	80	80WQS50-60-15	50	60	2900	15	60	30	~
26	80	80WQS25-80-15	25	80	2900	15	50	25	~
27	150	150WQS180-15-15	180	15	2900	15	67	45	GAK-150
28	200	200WQS300-7-15	300	7	2900	15	75	50	GAK-200
29	200	200WQS300-10-18.5	300	10	2900	18.5	75	50	GAK-200
30	150	150WQS150-20-18.5	150	20	2900	18.5	65	40	GAK-150
31	150	150WQS200-16-18.5	200	16	2900	18.5	70	45	GAK-150
32	100	100WQS100-30-18.5	100	30	2900	18.5	65	35	GAK-100
33	80	80WQS50-70-18.5	50	70	2900	18.5	60	30	~
34	80	80WQS50-80-22	50	80	2900	22	60	30	~
35	150	150WQS150-30-22	150	30	2900	22	65	40	GAK-150
36	200	200WQS300-12-22	300	12	2900	22	75	50	GAK-200
37	100	100WQS100-40-22	100	40	2900	22	65	35	GAK-100
38	100	100WQS100-50-22	100	50	2900	22	65	35	GAK-100
39	150	150WQS200-20-22	200	20	2900	22	70	45	GAK-150
40	65	65WQS25-100-25	300	100	2900	25	50	25	~
41	200	200WQS300-16-30	300	16	2900	30	75	50	GAK-200
42	100	100WQS100-60-30	100	60	2900	30	65	3545	GAK-100
43	150	150WQS200-30-30	200	30	2900	30	70	45	GAK-150
44	150	150WQS200-40-37	200	40	2900	37	70	45	GAK-150
45	200	200WQS300-20-37	300	20	2900	37	75	50	GAK-200